

# INSTRUCTION MANUAL

# Orion<sup>®</sup> Observer<sup>™</sup> 60mm AZ

#11042 60mm Altazimuth Refracting Telescope



 **ORION<sup>®</sup>**  
**TELESCOPES & BINOCULARS**  
*Providing Exceptional Consumer Optical Products Since 1975*

**Customer Support (800)-676-1343**  
**E-mail: [support@telescope.com](mailto:support@telescope.com)**  
**Corporate Offices (831)-763-7000**  
**89 Hangar Way, Watsonville, CA 95076**



Welcome to the exciting world of amateur astronomy. Your new Observer 60 Altazimuth Refractor is a quality optical instrument that will deliver countless hours of exciting stargazing, from magnified views of the Moon, star clusters and nebulas to glimpses of Jupiter’s moons and Saturn’s rings. The Observer 60 includes everything you need to go from box to backyard in less than half an hour.

These instructions will help you set up, use and care for your new telescope.

## Table of Contents

1. Unpacking . . . . .	3
2. Parts List . . . . .	3
3. The Basic Components of Your Telescope . . . . .	5
4. Assembly . . . . .	9
5. Getting Started . . . . .	10
6. Using your Telescope- Astronomical Viewing . . . . .	12
7. Specifications . . . . .	15

## 1. Unpacking

The entire telescope system will arrive in one box. Be careful unpacking the box since some of the contents are small and easy to overlook. We recommend keeping the original shipping container. In the event you need to ship the telescope to another location, or return it to Orion for warranty repair, having the proper shipping container will help ensure that your telescope will survive the journey intact.

Make sure all the parts in the parts list are present. Familiarize yourself with their features and compare them to the callouts on Figures 1, 2, and 3 when possible. If anything appears to be missing or broken, immediately call Orion Customer Support (1-800-676-1343) for assistance.

## 2. Parts List

Qty.	Description
1	Optical tube assembly (1)
1	“Yoke” altazimuth mount (5)
1	Altitude micro-motion control rod and thumbwheel (13)
3	Tripod legs (6) with attached accessory tray bracket (22)
1	Accessory tray (7)
1	EZ Finder II reflex sight (4)
3	Tripod attachment screws (21) with wingnuts and washers
3	Accessory tray attachment wing screws
3	Leg lock knobs (23)
2	“Yoke” knobs (18)
1	25mm Kellner eyepiece (3)
1	10mm Kellner eyepiece
1	Dust cover

***Warning: Never look directly at the Sun through your telescope or its finder scope—even for an instant—without a professionally made solar filter that completely covers the front of the instrument, or permanent eye damage could result. Young children should use this telescope only with adult supervision.***

---

# Observer™ 60 Refractor



**Figure 1.** Observer 60 Components

### 3. The Basic Components of Your Telescope

Figure 1 shows the fully assembled Observer 60 . All the major components of the telescope are described and numbered to help you identify each part and understand its use. Refer back to this figure when assembling the telescope.

#### 1 Optical tube

This is the main optical component of the telescope. The glass lens at the front of the tube gathers incoming light and focuses it by bending (or refracting) the light rays. The tube assembly has several parts built into it, which are shown and discussed in detail in the next section.

#### 2 90° Mirror star diagonal

The diagonal contains a mirror that reflects the light gathered through the optical tube to the eyepiece. The diagonal is angled to allow you to view objects that are high in the sky from a comfortable position.

#### 3 25mm Kellner eyepiece

The eyepiece is the part of the telescope that you actually look through to see things. The focal length of the eyepiece and the telescope determines the magnifying power of the telescope. Magnification is discussed in more detail in the Using Your Telescope section.

#### 4 EZ Finder II™ reflex sight

This is a special “finder” that helps you aim the telescope and locate objects in the sky for close-up viewing with your telescope. The EZ Finder II generates a red LED “dot” that shows where your telescope is aimed. The use of the EZ Finder II is discussed in the Getting Started section.

#### 5 “Yoke” altazimuth mount

The mount couples the telescope to the tripod and allows you to move the optical tube easily both up-and-down and right-and-left.

#### 6 Tripod legs

These aluminum tripod legs support the telescope and keep it steady. They can extend from 27" to 50" long.

#### 7 Accessory tray

This tray is a convenient place for holding extra eyepieces and other small pieces of equipment.

---

## Observer 60 Telescope Tube



**Figure 2a.** Optical tube components



**Figure 2b.** Observer 60 focuser detail

## Details of the Optical Tube and Components

Figure 2a shows the details of the optical tube and its various parts. The optical tube is shown attached to the mount for clarity. Figure 2b is a close-up of the focuser with even more detail.

### 8 Objective lens:

This is the main optical component of the telescope. It is an achromatic, fully coated 60mm lens.

### 9 Glare/Dew shield:

This is a simple “hood” for the objective lens that prevents dew from forming and stray light from hitting the lens.

### 10 Altitude castings:

These castings are built into the optical tube. The “yoke” knobs thread into these castings through the holes in the top of the “yoke” altazimuth mount to secure the two parts together.

### 11 EZ Finder II mounting bracket:

The EZ Finder II is secured to this bracket located on the optical tube.

### 12 Micro-motion rod attachment post:

This post is where the micro-motion rod will be attached to the optical tube.

### 13 Altitude micro-motion control rod and thumb-wheel:

This allows fine adjustment of the telescope in the altitude (up-down) direction. For more details, see the Getting Started section.

### 14 Focuser drawtube:

This is where the 90° mirror star diagonal, or other optional diagonal, is inserted. The drawtube is adjusted by the turning the focus wheel, which adjusts a rack-and-pinion system to bring objects into focus.

### 15 Focus wheels:

These wheels, when turned, move the focuser drawtube in or out. Use it to bring things into focus when you are looking in the eyepiece.

### 16 Diagonal holder thumbscrews:

These two thumbscrews secure the 90° mirror star diagonal into the focuser drawtube. These should only be loosened to remove or rotate the star diagonal.

### 17 Eyepiece holder thumbscrew:

This thumbscrew holds the eyepiece in position. Tighten it after inserting an eyepiece; loosen it before removing or changing eyepieces.

### 18 “Yoke” knobs:

These knobs secure the optical tube to the “yoke” altazimuth mount. They should always be securely tightened.

## Observer 60 Tripod and Mount

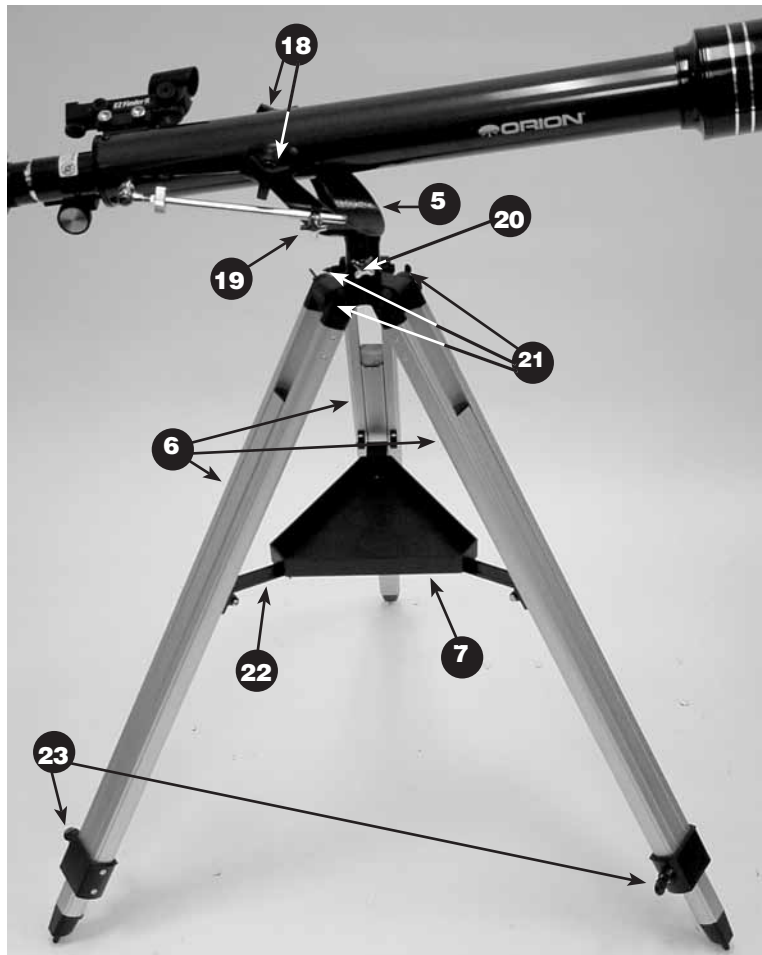

**Figure 3a.** Tripod and mount detail

### Details of the Tripod and Mount

Figure 3a shows a close up of the telescope's mount and tripod. Important features are pointed out for greater clarity and detail.

#### **19** Altitude lock knob:

This locks the telescope in the altitude (up/down) direction. Keep this knob tightened unless you are moving the telescope a significant distance in the altitude direction. For smaller altitude adjustments, use the altitude micro-motion control rod and thumbwheel.

#### **20** Azimuth lock knob:

This locks the telescope in the azimuth (left/right) direction. Keep this knob tightened unless you are adjusting the telescope in the azimuth direction.

#### **21** Tripod leg attachment screws:

These screws attach the tripod legs to the “yoke” altazimuth mount. Each screw has a wingnut and two washers.

#### **22** Accessory tray bracket:

This bracket holds the accessory tray.

#### **23** Leg lock knobs:

These knobs lock the tripod legs into place. Loosen them to lengthen or shorten the tripod legs. Tighten them once you have the legs at the desired length. Be certain that all three tripod legs are equally extended to assure your telescope is level.

These items are included with your telescope, but are not shown in Figures 1, 2 or 3.

**10mm Kellner eyepiece:** This is a second, high-powered eyepiece, providing 70x magnification. For more details see the Using Your Telescope section.

**Dust cover:** Use this to cover the objective lens when the telescope is not in use. It will prevent dust from collecting on the objective lens.



## 4. Assembly

Assembling the telescope for the first time should take about 30 minutes. The only tools you will need are a Phillips head screwdriver and a flat head screwdriver. As a general note, tighten all screws securely to eliminate flexing and wobbling, but be careful not to over-tighten and thereby strip the threads. Refer to Figures 1 through 4 during the assembly process.

During assembly (and any other time, for that matter), do not touch the surfaces of the telescope objective lens or the lenses of the finder scope and eyepiece with your fingers. These optical surfaces have delicate coatings that can easily be damaged if touched. Never remove any lens assembly from its housing for any reason, or the product warranty will be voided.

Begin set-up of the telescope by assembling the tripod and mount first:

1. Lay the “Yoke” altazimuth mount (5) on its side. Attach the tripod legs (6), one at a time, to the base of the mount by sliding a tripod leg attachment screw (21) through the top of a leg and through the holes in the base of the mount. The washers should be on the outside of the tripod legs. Secure the wing nuts finger-tight. Figure 3b shows a close-up detail of the screws attaching the tripod legs to the altazimuth mount.
2. Install and tighten the leg lock knobs (23) on the bottom braces of the tripod legs (6). For now, keep the legs at their shortest (fully retracted) length; you can extend them to a more desirable length later, once the tripod is completely assembled.
3. Stand the tripod and mount upright and spread the tripod legs apart as far as they will go, until the accessory tray bracket (22) is taut. Connect the accessory tray (7) to the accessory tray bracket (22) with the three wing screws already installed in the tray. Push the wing screws up through the holes in the accessory tray bracket and thread them into the holes in the accessory tray.
4. Tighten the tripod leg attachment screws (21) at the tops of the tripod legs so the legs are securely fastened to the

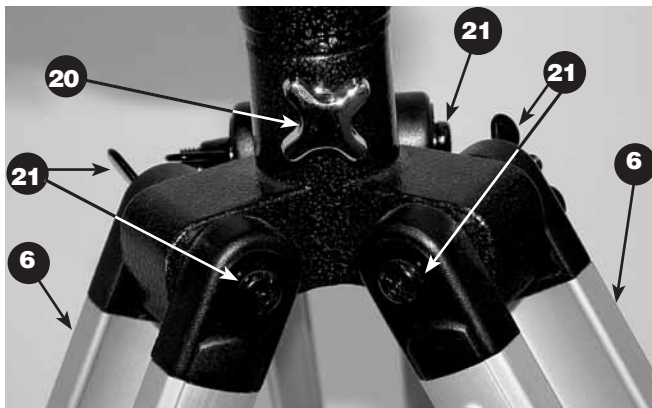

**Figure 3b.** Observer 60 Tripod leg and mount attachment detail

mount. Use the Phillips head screwdriver and/or your fingers to do this.

5. Attach the altitude micro-motion rod and thumbwheel (13) to the optical tube by first removing the flat-head screw from the micro-motion rod attachment post (12) on the side of the optical tube. Slide the screw through the hole at the end of the micro-motion rod and rethread the screw into the attachment post. Make sure the screw is tightened.

The tripod is now completely assembled and the “yoke” altazimuth mount is ready for the installation of the optical tube

6. To install the optical tube (1) in the “yoke” altazimuth mount (5), first slide the altitude micro-motion control rod into its receptacle, at the same location as the altitude lock knob (19) on the side of the yoke. (Figure 4). Then, with the rod in place in the receptacle, gently drop the optical tube into the yoke so that the holes on the altitude castings (10) on the side of the optical tube line up with the holes on the top of the “yoke” altazimuth mount. Slide the yoke knobs (18) through the holes on top of the mount and thread them into the altitude castings on the optical tube. Tighten the altitude lock knob (19) securely.
7. Attach the EZ Finder II reflex sight (4) to the EZ Finder II mounting bracket (11). Loosen the two securing screws on the EZ Finder II (Figure 6) and slide it onto the mounting bracket. Tighten the two securing screws. You will align the EZ Finder II later, in the Getting Started section.
8. Insert the chrome barrel of the 90° mirror star diagonal (2) into the focuser drawtube (14). Secure the mirror star diagonal with the diagonal holder thumbscrews (16).
9. Insert the chrome barrel of the 25mm Kellner eyepiece (3) into the 90° mirror star diagonal. Secure the eyepiece in the diagonal with the eyepiece holder thumbscrew (17). The eyepiece and diagonal properly installed should look like Figure 2b.

Your telescope is now fully assembled.



**Figure 4.** Installing the optical tube in the “yoke” altazimuth mount

## 5. Getting Started

Now that your Observer 60 is assembled, you're ready to begin observing. This section will instruct you on using your telescope effectively.

### Altitude and Azimuth (Aiming the Telescope)

The Observer 60 altazimuth mount permits motion along two axes: altitude (up/down) and azimuth (left/right). See Figure 5. Moving the telescope up/down and right/left is the "natural" way people aim objects and this makes pointing the telescope intuitive and easy.

To move the telescope in the azimuth direction, loosen the azimuth lock knob, take hold of the telescope by the "yoke", and gently rotate the telescope to the desired position. Then re-tighten the azimuth lock knob. To move the telescope in the altitude direction, loosen the altitude lock knob, take hold of the end of the optical tube and move the tube up or down to the desired position. Then re-tighten the altitude lock knob.

### Note about the Altitude Micro-Motion Rod and Thumbwheel

Since making fine adjustments to the altitude of the telescope can be tricky, the Observer 60 comes with an altitude micro-motion rod and thumbwheel. By turning the thumbwheel, the telescope will move very slightly either up or down, depending on which direction you turn the thumbwheel. Since there is a limit to how far the thumbwheel can turn in either direction, if you need to make any large altitude movements to the telescope it is best to simply loosen the altitude lock knob and move the scope by hand.



**Figure 5** The Observer 60 has two axes of motion: altitude and azimuth.

### Focusing the Telescope

With the 25mm Kellner eyepiece inserted into the 90° mirror star diagonal and secured with the thumbscrews, aim the optical tube so the front (open) end is pointing in the general direction of an object at least 1/4-mile away. Now, with your fingers, slowly rotate one of the focus wheels until the object comes into sharp focus. Go a little bit beyond sharp focus until the image starts to blur again, then reverse the rotation of the knob, just to make sure you've hit the exact focus point.

### Do You Wear Eyeglasses?

If you wear eyeglasses, you may be able to keep them on while you observe. In order to do this, your eyepiece must have enough "eye relief" to allow you to see the entire field of view with glasses on. You can try looking through the eyepiece first with your glasses on and then with them off, to see if the glasses restrict the view to only a portion of the full field. If the glasses do restrict the field of view, you may be able to observe with your glasses off by just refocusing the telescope to your unaided vision.

If your eyes are astigmatic, images will probably appear best with glasses on. This is because a telescope's focuser can accommodate for nearsightedness or farsightedness, but not astigmatism. If you have to wear your glasses while observing and cannot see the entire field of view, you may want to purchase additional eyepieces that have longer eye relief.

Short eye relief restricts the field of view for eyeglass wearers.



Long eye relief allows full field of view to be seen with or without eyeglasses.



### Operating the EZ Finder II reflex finder

The EZ Finder II reflex finder (Figure 6) works by projecting a tiny red dot onto a lens mounted in the front of the unit. When you look through the EZ Finder II, the red dot will appear to float in space, helping you locate even the faintest of deep space objects. The red dot is produced by a light-emitting diode (LED), not a laser beam, near the rear of the sight. A replaceable 3-volt lithium battery provides the power for the diode.

To use the EZ Finder II, turn the power knob clockwise until you hear a “click” indicating that power has been turned on. With your eyes positioned a comfortable distance from the back of the sight, look through the back of the reflex sight with both eyes open to see the red dot. The intensity of the dot can be adjusted by turning the power knob. For best results when stargazing, use the dimmest possible setting that allows you to see the dot without difficulty. Typically, a dim setting is used under dark skies and a bright setting is used under light-polluted skies or in daylight.

At the end of your observing session, be sure to turn the power knob counterclockwise until it clicks off. When the two white dots on the EZ Finder II’s rail and power knob are lined up, the EZ Finder II is turned off.

### Aligning the EZ Finder II

When the EZ Finder II is properly aligned with the telescope, an object that is centered on the EZ Finder II’s red dot should also appear in the center of the field of view of the telescope’s eyepiece. Alignment of the EZ Finder II is easiest during daylight, before observing at night. Aim the telescope at a distant object at least 1/4 mile away, such as a telephone pole or chimney and

center it in the telescope’s eyepiece. Now, turn the EZ Finder II on and look through it. The object will appear in the field of view near the red dot.

**Note: The image in the eyepiece of the Observer 60 will be reversed from left-to-right. This is normal for a refractor telescope using mirror star diagonal.**

Without moving the telescope, use the EZ Finder II’s azimuth (left/right) and altitude (up/down) adjustment wheels to position the red dot on the object in the eyepiece.

When the red dot is centered on the distant object, check to make sure that the object is still centered in the telescope’s field of view. If not, recenter it and adjust the EZ Finder II’s alignment again. When the object is centered in the eyepiece and on the red dot, the EZ Finder II is properly aligned with the telescope. Figure 7 shows how the view through the EZ Finder may look while you are aligning it.

Once aligned, EZ Finder II will usually hold its alignment even after being removed and remounted. Otherwise, only minimal realignment will be needed.

### Replacing the EZ Finder II Battery

Should the battery ever die, replacement 3-volt lithium batteries are available from many retail outlets. Remove the old battery by inserting a small flat-head screwdriver into the slot on the battery cover (Figure 6) and gently prying open the cover. Then carefully pull back on the retaining clip and remove the old battery. Do not overbend the retaining clip. Then slide the new battery under the battery lead with the positive (+) side facing down and replace the battery cover.

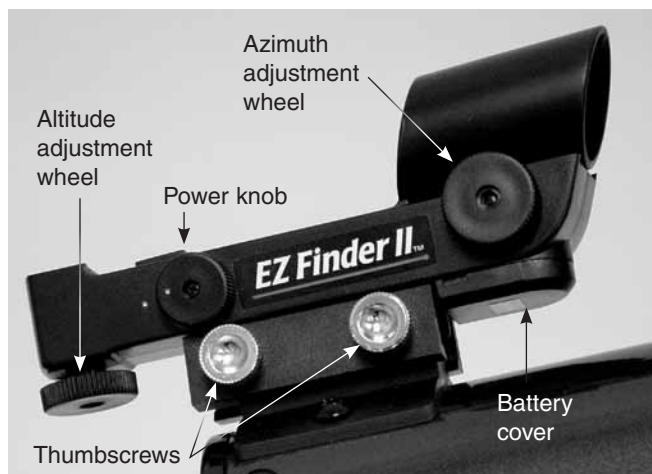

**Figure 6.** The EZ Finder II reflex sight



**Figure 7.**

EZ Finder II superimposes a tiny red dot on the sky, showing right where the telescope is pointed.

## 6. Using Your Telescope - Astronomical Observing

### Choosing an Observing Site

When selecting a location for observing, get as far away as possible from direct artificial light such as street lights, porch lights, and automobile headlights. The glare from these lights will greatly impair your dark-adapted night vision. Set up on a grass or dirt surface, not asphalt, because asphalt radiates more heat, which disturbs the surrounding air and degrades the images seen through the telescope. Avoid viewing over rooftops and chimneys, as they often have warm air currents rising from them. Similarly, avoid observing from indoors through an open (or closed) window, because the temperature difference between the indoor and outdoor air will cause image blurring and distortion.

If at all possible, escape the light-polluted city sky and head for darker country skies. You'll be amazed at how many more stars and deep-sky objects are visible in a dark sky!

### "Seeing" and Transparency

Atmospheric conditions vary significantly from night to night. "Seeing" refers to the steadiness of the Earth's atmosphere at a given time. In conditions of poor seeing, atmospheric turbulence causes objects viewed through the telescope to "boil". If, when you look up at the sky with your naked eyes, the stars are twinkling noticeably, the seeing is bad and you will be limited to viewing with low powers (bad seeing affects images at high powers more severely). Planetary observing may also be poor.

In conditions of good seeing, star twinkling is minimal and images appear steady in the eyepiece. Seeing is best overhead, worst at the horizon. Also, seeing generally gets better after midnight, when much of the heat absorbed by the Earth during the day has radiated off into space.

Especially important for observing faint objects is good "transparency" air free of moisture, smoke, and dust. All tend to scatter light, which reduces an object's brightness. Transparency is judged by the magnitude of the faintest stars you can see with the unaided eye (6th magnitude or fainter is desirable).

If you cannot see stars of magnitude 3.5 or dimmer then conditions are poor. Magnitude is a measure of how bright a star is - the brighter a star is, the lower its magnitude will be. A good star to remember for this is Megrez (mag. 3.4), which is the star in the "Big Dipper" connecting the handle to the "dipper". If you cannot see Megrez, then you have fog, haze, clouds, smog, or other conditions that are hindering your viewing. (See Figure 8).

### Tracking Celestial Objects

The Earth is constantly rotating about its polar axis, completing one full rotation every 24 hours; this is what defines a "day". We do not feel the Earth rotating, but we can still tell that it is at night by seeing the apparent movement of stars from east to west.

When you observe any astronomical object, you are watching a moving target. This means the telescope's position must be continuously adjusted over time to keep an object in the field of view. When viewing the with the Observer 60, you will need to give the optical tube a light tug or push in azimuth (left or right) as well as an occasional turn of the altitude micro-motion thumbwheel)

to keep the object in the field of view. (Make certain the azimuth lock knob is slightly loosened before moving the scope in the azimuth position.) Objects will appear to move faster at higher magnifications because the field of view is narrower.

Remember that objects are reversed left to right in refractor telescopes, so when you move the telescope in one direction in the azimuth, the object will move in the opposite direction in the eyepiece. This takes some getting used to, but becomes second nature after a few nights out with the telescope.

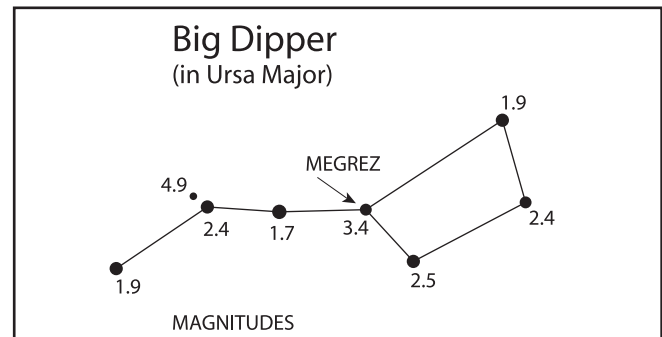

**Figure 8.** Megrez connects the Big Dipper's handle to its "pan". It is a good guide to how conditions are. If you cannot see Megrez (a 3.4 mag star) then conditions are poor.

### Light Pollution

Most of us live where city lights interfere with our view of the heavens. As our metropolitan areas have become more developed, the scourge of light pollution has spread, washing out many stars and nonstellar celestial objects from our sight. Faint deep sky objects become difficult or impossible to see through the murk of light pollution. Even bright nebulas like the Orion and Lagoon Nebulas lose much of their delicate detail. The Moon and planets are not affected; they require steady air more than dark skies, so they remain good targets for city-dwelling observers.

The International Dark-Sky Association is waging the fight against light pollution. The IDSA was founded in 1988 with the mission of educating the public about the adverse impact that light pollution has on the night sky and astronomy. Through educational and scientific means, the nonprofit IDA works to raise awareness about the problem and about measures that can be taken to solve it.

Do you need help dealing with local officials to control street or building lighting in your area? The IDA's extensive support materials can show you how. Help preserve dark skies, join the IDA today! For information, write to IDA, 3225 N. First Ave., Tucson, AZ 85719-2103 or visit their website: [www.darksky.org](http://www.darksky.org).

The best way to avoid immediate problems with light pollution, however, is to take your telescope to where there are dark skies. You will be amazed at how many stars you can see when you get away from the city lights.

## Eyepiece Selection

By using eyepieces of different focal lengths, it is possible to attain many magnifications or powers with the Observer 60. Your telescope comes with two Kellner eyepieces (Figure 9): a 25mm, which gives a magnification of 28x, and a 10mm, which gives a magnification of 70x. Other eyepieces can be used to achieve higher or lower powers. It is quite common for an observer to own five or more eyepieces to access a wide range of magnifications.

To calculate the magnification, or power, of a telescope-eyepiece combination, simply divide the focal length of the telescope by the focal length of the eyepiece.

$$\text{Telescope Focal Length (mm)} \div \text{Eyepiece Focal Length(mm)} = \text{Magnification}$$

For example, the Observer 60, which has a focal length of 700mm, used in combination with the 25mm eyepiece, yields a magnification of

$$700 \div 25 = 28x$$

Whatever you choose to view, always start by inserting your lowest-power (longest focal length) eyepiece to locate



**Figure 9.** The 25mm and 10mm Kellner eyepieces.

and center the object. Low magnification yields a wide field of view, which shows a larger area of sky in the eyepiece. This makes finding and centering an object much easier. Trying to find and center objects with a high power (narrow field of view) eyepiece is like trying to find a needle in a haystack!

Once you've centered the object in the eyepiece, you can switch to a higher magnification (shorter focal length) eyepiece, if you wish. This is recommended for small and bright objects, like planets and double stars. The Moon also takes higher magnifications well.

The best rule of thumb with eyepiece selection is to start with a low power, wide-field eyepiece, and then work your way up in magnification. If the object looks better, try an even higher magnification eyepiece. If the object looks worse, then back off the magnification a little by using a lower-power eyepiece.

### Magnification Limits

Every telescope has a useful magnification limit of about 2X per millimeter of aperture. This comes to 120X for the Observer 60. Some telescope manufacturers will use misleading claims of excess magnification, such as "See distant galaxies at 640X!". While such magnifications are technically possible, the actual image at that magnification would be an indistinct blur.

Moderate magnifications are what give the best views. It is better to view a small, but bright and detailed image than a dim, unclear, oversized image.

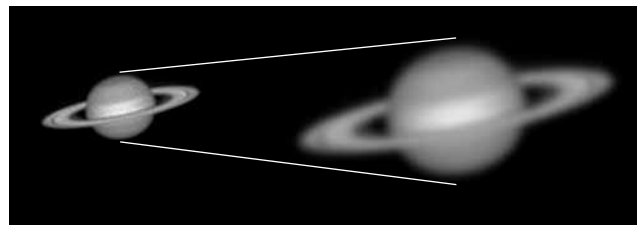



---

## What to Expect

So what will you see with your telescope? You should be able to see bands on Jupiter, the rings of Saturn, craters on the Moon, the waxing and waning of Venus, and many bright deep-sky objects. Do not expect to see color as you do in NASA photos, since those are taken with long-exposure cameras and have “false color” added. Our eyes are not sensitive enough to see color in deep-sky objects except in a few of the brightest ones.

Remember that you are seeing these objects using your own telescope with your own eyes! The object you see in your eyepiece is in real-time, and not some conveniently provided image from an expensive space probe. Each session with your telescope will be a learning experience. Each time you work with your telescope it will get easier to use, and stellar objects will become easier to find. Take it from us, there is big difference between looking at a well-made full-color NASA image of a deep-sky object in a lit room during the daytime, and seeing that same object in your telescope at night. One can merely be a pretty image someone gave to you. The other is an experience you will never forget!

## Objects to Observe

Now that you are all set up and ready to go, one critical decision must be made: what to look at?

### A. The Moon

With its rocky surface, the Moon is one of the easiest and most interesting targets to view with your telescope. Lunar craters, maria, and even mountain ranges can all be clearly seen from a distance of 238,000 miles away! With its ever-changing phases, you'll get a new view of the Moon every night. The best time to observe our one and only natural satellite is during a partial phase, that is, when the Moon is NOT full. During partial phases, shadows are cast on the surface, which reveal more detail, especially right along the border between the dark and light portions of the disk (called the “terminator”). A full Moon is too bright and devoid of surface shadows to yield a pleasing view. Make sure to observe the Moon when it is well above the horizon to get the sharpest images.

Use an optional Moon filter to dim the Moon when it is very bright. It simply threads onto the bottom of the eyepieces (you must first remove the eyepiece from the focuser to attach a filter). You'll find that the Moon filter improves viewing comfort, and also helps to bring out subtle features on the lunar surface.

### B. The Sun

You can change your nighttime telescope into a daytime Sun viewer by installing an optional full-aperture solar filter over the front opening of the Observer 60. The primary attraction is sunspots, which change shape, appearance, and location daily. Sunspots are directly related to magnetic activity in the Sun. Many observers like to make drawings of sunspots to monitor how the Sun is changing from day to day.

**Important Note: Do not look at the Sun with any optical instrument without a professionally made solar filter, or permanent eye damage could result.**

## C. The Planets

The planets don't stay put like the stars, so to find them you should refer to Sky Calendar at our website (telescope.com), or to charts published monthly in *Astronomy*, *Sky & Telescope*, or other astronomy magazines. Venus, Mars, Jupiter, and Saturn are the brightest objects in the sky after the Sun and the Moon. Your Observer 60 is capable of showing you these planets in some detail. Other planets may be visible but will likely appear star-like. Because planets are quite small in apparent size, optional higher-power eyepieces are recommended and often needed for detailed observations. Not all the planets are generally visible at any one time.

**JUPITER:** The largest planet, Jupiter, is a great subject for observation. You can see the disk of the giant planet and watch the ever-changing positions of its four largest moons - Io, Callisto, Europa, and Ganymede.

**SATURN:** The ringed planet is a breathtaking sight when it is well positioned. The tilt angle of the rings varies over a period of many years; sometimes they are seen edge-on, while at other times they are broadside and look like giant “ears” on each side of Saturn's disk. A steady atmosphere (good seeing) is necessary for a good view. You will probably see a bright “star” close by, which is Saturn's brightest moon, Titan.

**VENUS:** At its brightest, Venus is the most luminous object in the sky, excluding the Sun and the Moon. It is so bright that sometimes it is visible to the naked eye during full daylight! Ironically, Venus appears as a thin crescent, not a full disk, when at its peak brightness. Because it is so close to the Sun, it never wanders too far from the morning or evening horizon. No surface markings can be seen on Venus, which is always shrouded in dense clouds.

**MARS:** The Red Planet makes its closest approach to Earth every two years. During close approaches you'll see a red disk, and may be able to see the polar ice cap.

## D. The Stars

Stars will appear like twinkling points of light. Even powerful telescopes cannot magnify stars to appear as more than a point of light. You can, however, enjoy the different colors of the stars and locate many pretty double and multiple stars. The famous “Double-Double” in the constellation Lyra and the gorgeous two-color double star Albireo in Cygnus are favorites. Defocusing a star slightly can help bring out its color.

## E. Deep-Sky Objects

Under dark skies, you can observe a wealth of fascinating deep-sky objects, including gaseous nebulas, open and globular star clusters, and a variety of different types of galaxies. Most deep-sky objects are very faint, so it is important that you find an observing site well away from light pollution. Take plenty of time to let your eyes adjust to the darkness. Do not expect these subjects to appear like the photographs you see in books and magazines; most will look like dim gray smudges. But as you become more experienced and your observing skills get sharper, you will be able to ferret out more and more subtle details and structure.

To find deep sky objects in the sky, it is best to consult a star chart or planisphere. These guides will help you locate

---

the brightest and best deep-sky objects for viewing with your Observer 60.

### **Terrestrial Viewing**

The Observer 60 can be used for long-distance viewing over land. We recommend using an optional 45° correct-image prism diagonal instead of the included 90° mirror star diagonal. The correct-image diagonal will yield upright, non-reversed images and provide a more comfortable viewing angle.

For terrestrial viewing, it's best to stick with low-powered eyepieces that yield a magnification under 80x. At higher powers, images rapidly lose sharpness and clarity due to "heat waves" caused by Sun-heated air.

Remember to aim well clear of the Sun, unless the front of the telescope is fitted with a professionally made solar filter.

### **Care and Maintenance**

If you give your telescope reasonable care, it will last a lifetime. Store it in a clean, dry, dust free place, safe from rapid changes in temperature and humidity. Do not store the telescope outdoors, although storage in a garage or shed is OK. Small components like eyepieces and other accessories should be kept in a protective box or storage case. Keep the caps on the front of the telescope and on the focuser drawtube when not in use.

Your Observer 60 telescope requires very little mechanical maintenance. The optical tube is aluminum and has a smooth painted finish that is fairly scratch resistant. If a scratch does appear, it will not harm the telescope.

### **Cleaning Lenses**

Any quality optical lens cleaning tissue and optical lens cleaning fluid specifically designed for multi-coated optics can be used to clean the Observer 60's objective lens and exposed lenses of your eyepieces. Never use regular glass cleaner or cleaning fluid designed for eyeglasses.

Before cleaning with fluid and tissue, blow any loose particles off the lens with a blower bulb or compressed air. Then apply some cleaning fluid to a tissue, never directly on the optics. Wipe the lens gently in a circular motion, then remove any excess fluid with a fresh lens tissue. Oily fingerprints and smudges may be removed using this method. Use caution - rubbing too hard may scratch the lens. For the larger surface of the objective lens, clean only a small area at a time, using a fresh lens tissue on each area. Never reuse tissues.

## **7. Specifications**

Optical tube: Aluminum

Objective lens diameter: 60mm

Objective lens: Achromatic, air-spaced, coated

Focal length: 700mm

Focal ratio: f/11.7

Focuser: Rack and pinion, accepts 1.25" eyepieces

Eyepieces: 25mm and 10mm Kellner eyepieces, 1.25"

Magnification: 28x (with 25mm) and 70x (with 10mm)

Tripod: Aluminum

Mount: Altazimuth yoke, fine adjustment for altitude

Star diagonal: Mirror, 1.25"

Finder: EZ Finder II reflex sight

Weight: 5.7 lbs.

---

## **One-Year Limited Warranty**

This Orion Observer™ 60 Altazimuth is warranted against defects in materials or workmanship for a period of one year from the date of purchase. This warranty is for the benefit of the original retail purchaser only. During this warranty period Orion Telescopes & Binoculars will repair or replace, at Orion's option, any warranted instrument that proves to be defective, provided it is returned postage paid to: Orion Warranty Repair, 89 Hangar Way, Watsonville, CA 95076. If the product is not registered, proof of purchase (such as a copy of the original invoice) is required.

This warranty does not apply if, in Orion's judgment, the instrument has been abused, mishandled, or modified, nor does it apply to normal wear and tear. This warranty gives you specific legal rights, and you may also have other rights, which vary from state to state. For further warranty service information, contact: Customer Service Department, Orion Telescopes & Binoculars, 89 Hangar Way, Watsonville, CA 95076; (800)-676-1343.

### **Orion Telescopes & Binoculars**

**89 Hangar Way, Watsonville, CA 95076**

**Customer Support Help Line (800)-676-1343 • Day or Evening**