

4

3

2

1

NOTES: UNLESS OTHERWISE SPECIFIED:

- 1. PLATE MUST NOT HAVE TILT ON C-C AXIS
- 2. TYP RADIUS 1/4"
- 3. 10" OD PIPE X 33" LONG

DRILL 9/16 THRU (2)  
120 DEG TYP  
ON 13.500 B.C.D.

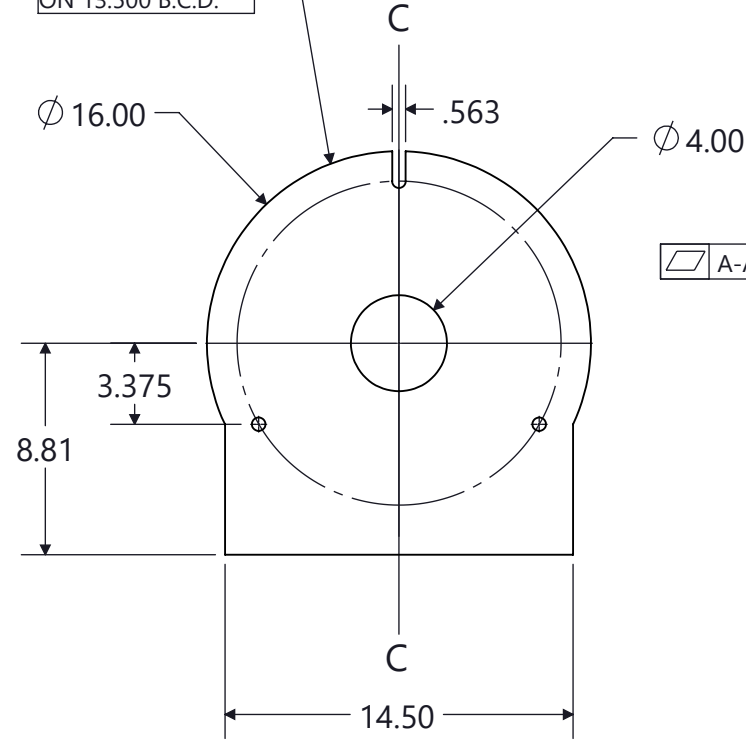

SECTION A-A  
SCALE 1 : 8

A-A 1/32" TIR

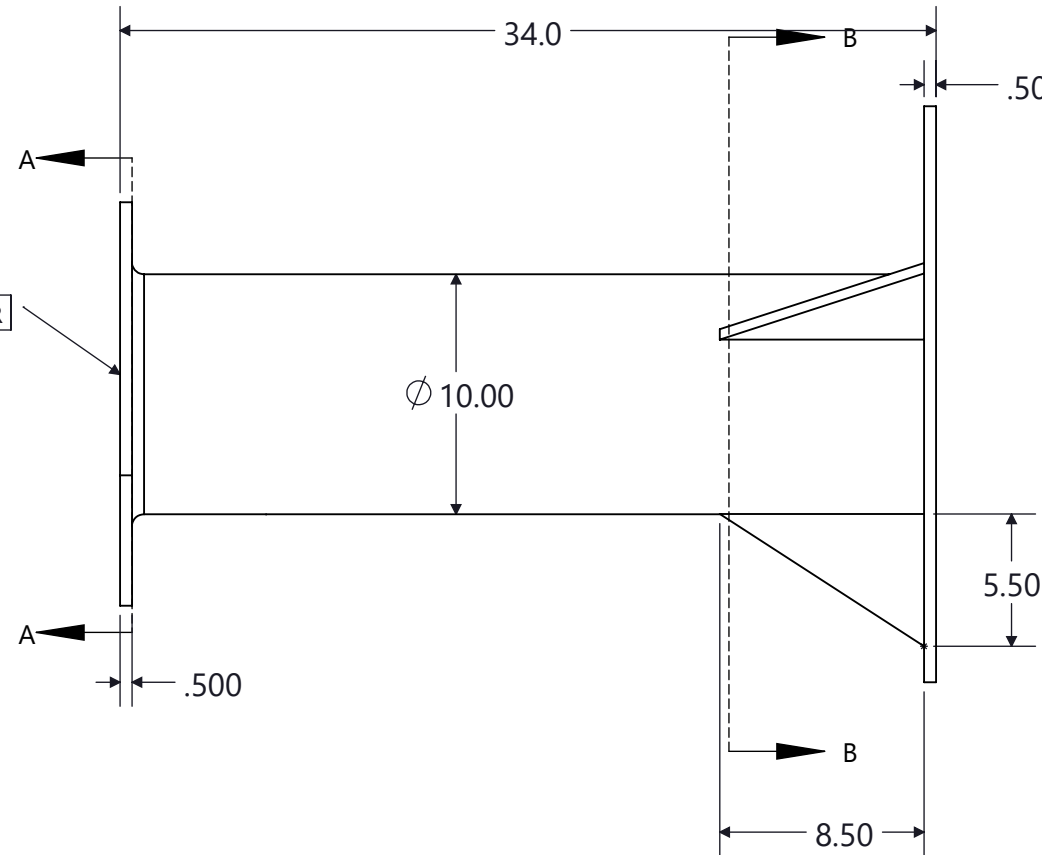

SLOT 3/4 THRU (3)  
BY 5.0 DEGREE ARC  
120 DEG TYP  
ON 20.00 B.C.D

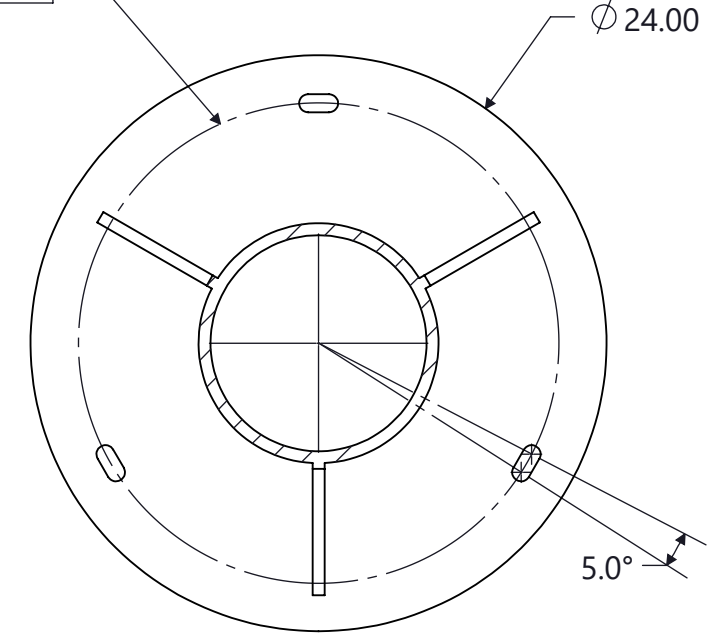

SECTION B-B  
SCALE 1 : 8

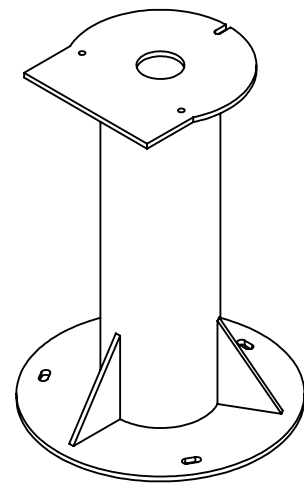

THIRD ANGLE PROJECTION:

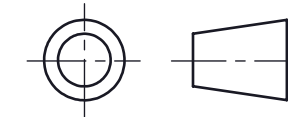

TITLE:  
**PIER, ALTAZIMUTH, 16SC  
BLACK**

UNLESS OTHERWISE SPECIFIED: DIMENSIONS ARE IN INCHES.

DIMENSIONS IN BRACKETS [ ] ARE IN MM.  
PARENTHESIS ( ) ARE REFERENCE.  
INTERPRET GEOMETRIC TOLERANCING PER:  
ASME Y14.5M-1994

DECIMALS	.XX ± 0.01 .XXX ± 0.005
ANGULAR	± 0.5°

MATERIAL

STEEL

FINISH

POWDERCOAT BLACK

Drawn By

SCALE:  
1:12

SHEET  
1 OF 1

SIZE

**B**

DWG. NO.

42-1600-02

REV

I

4

3

2

1

B

B

A

A